

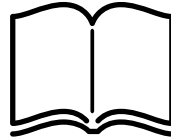

# Assembly and use guide

## PROFESSIONAL SCAFFOLDING SYSTEMS ( ProTUBE L - S - F )



The instructions for the assembly  
and use shall be followed carefully

**EN1004**

201612-IE-1210

# TABLE OF CONTENTS

1. Introduction.....	3
2. General .....	3
2.1 Usage .....	3
2.2 Necessary Additional Instructions for Usage of ProTUBE Scaffolds .....	4
2.3 Check List for Usage of ProTUBE Scaffold .....	5
2.4 Examination, Storage and Maintenance .....	6
2.5 Disassembly of ProTUBE Scaffolds .....	6
2.6 Relocation of ProTUBE Scaffolds .....	6
2.7 Assembly and/or Repair of Spare Parts .....	7
2.8 Guarantee Conditions .....	7
2.9 Fastening of Frames .....	7
3. ProTUBE L (Wide) Aluminum Scaffold System .....	8
3.1 ProTUBE L Configuration Table .....	9
3.2 ProTUBE L6 Scaffold Assembly Method .....	10
3.3 ProTUBE L (Wide) Aluminum Scaffold System 3D Pictures .....	16-17
3.4 ProTUBE L Scaffold System Compounds .....	18
4. ProTUBE S (Narrow) Aluminum Scaffold System .....	19
4.1 ProTUBE S Configuration Table .....	19
4.2 ProTUBE S6 Scaffold Assembly Method .....	20
4.3 ProTUBE S (Narrow) Aluminum Scaffold System 3D Images .....	25
4.4 ProTUBE S Scaffold Systems Compounds .....	26
5. ProTUBE F (Foldable) Aluminum Scaffold System .....	27
5.1 ProTUBE F Configuration Table .....	27
5.2 ProTUBE F6 Scaffold Assembly Method .....	28
5.3 ProTUBE F (Foldable) Aluminum Scaffold System 3D Images.....	33
5.4 ProTUBE F Scaffold Systems Compounds .....	34

# 1. Introduction

This assembly and usage hand book is prepared with for the usage of Professional Aluminum Scaffolds (Narrow-Wide-Folding) which will be referred to as ProTUBE Scaffolds together its configuration. Before starting to the assembly of ProTUBE Scaffolds carefully read these instructions. The required scaffold should be assembled and used in accordance with these instructions.

All instructions in this handbook must be exactly complied with.

In case of failure to comply with the instructions of this handbook an accident may occur. Çağsan Merdiven shall not be responsible for assembly and usage of ProTUBE Scaffolds manufactured by Çağsan Merdiven Company in violation to this handbook.

Employer, supervisor and user shall be responsible for the correct usage of the scaffold in accordance with this handbook and to keep this handbook ready where ProTUBE Scaffold is used.

## 2. General

For Standard ProTUBE Scaffold configurations see the configurations table in this handbook.

ProTUBE Scaffold can only be assembled, disassembled or modified under the supervision of an authorized person and by people who are trained for the related specific risks;

- Understanding of assembly, disassembly or transformation plan of ProTUBE Scaffolds;
- Assembly, disassembly or transformation of ProTUBE Scaffolds securely;
- Measures for prevention of risks towards people or objects; Safety measures for weather conditions which may negatively affect security of the ProTUBE Scaffolds
- Permitted load;

Other risks to occur as a result of above mentioned assembly, disassembly or transformation works.

The people who are responsible for the job shall be able to reach this handbook.





Only original Çağsan Merdiven parts should be used for assembly.



Standard Çağsan Merdiven - ProTUBE Scaffold configurations meet the European Standard EN1004.

Please take in consideration the national or local regulations before use the working tower. If available and possible to perform successfully the people working on the fitting should be connected to the outer wall for additional personal security. People should not connect themselves to the scaffold unless scaffold is fixed to the wall.

## 2.1 Usage

Çağsan Merdiven ProTUBE Scaffolds can be used in heights.

Product	Max Platform Height	
	Indoor	Outdoor
ProTUBE L 	12,20 m.	4,63 m.
ProTUBE L 	12,20 m.	8,00 m.
ProTUBE S 	6,50 m.	6,50 m.
ProTUBE F 	4,40 m.	4,40 m.

- Maximum load per platform is 2,0 kN/m<sup>2</sup>
- EN 1004-2-4,63/12,20-XXXD (ProTUBE L) (TUV-SUD Mark) 
- TS EN 1004-3-8,00/12,20-H2 XXXD (ProTUBE L) (TSE Mark) 
- The horizontal loads that result from the works to be made on ProTUBE Scaffolds and which exceed 30 kg should not be permitted.
- If there are excessive winds, ProTUBE Scaffolds should be fixed.
- ProTUBE Scaffolds can only be used on horizontal, straight and solid surfaces.
- ProTUBE Scaffolds should not be used with wind speed more than 38 km/h (max. 6 Beaufort).

- ProTUBE Scaffolds should not be used for storm, snow, ice, excessive rain or lightning
- Do not lift or held with a crane ProTUBE Scaffolds.
- ProTUBE Scaffolds should not be used for access to other structures.
- Standard configuration calculations cannot include canvas and/or advertising display usage calculations.

## 2.2 Necessary Additional Instructions for Usage of ProTUBE Scaffolds

- While working with ProTUBE Scaffolds work shoes, work gloves and helmet must be worn.
- ProTUBE Scaffolds should not be climbed from outer side and support, cross and horizontal parts should never be stepped on.
- Don't increase the height of the platform you are working on with a ladder, crate etc. (Diagram 1)



- The floor measurements of the platforms of the scaffold cannot be increased by using different materials.
- Lifting equipment usage on the ProTUBE Scaffolds should not be permitted. This may seriously affect the balance. (Diagram 2);
- The parts and tools on the working floor of ProTUBE Scaffolds can only be manually carried.
- If ProTUBE Scaffolds are to be placed on a soft surface, there should be protection plates or U-profiles under the wheels, (Diagram 3)

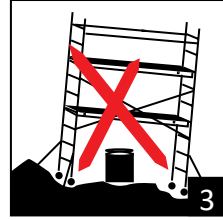
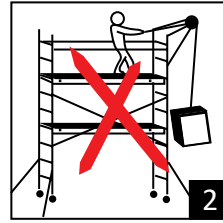

- Wind load should be taken into consideration in areas that are affected by wind such as open constructions, building corners etc. Scaffold usage should be stopped under wind powers that exceed 38 km/h (max. 6 Beaufort). It should not be transferred. If possible it should be fixed to the wall and ProTUBE Scaffold should be transferred to a place without wind when the wind power decreases. (Diagram 4)



- National regulations and the measures should be taken into consideration for the wind loads.
- Additional working platform and other objects should not be placed on the outer side of ProTUBE Scaffolds.
- The vertical line of the ProTUBE Scaffolds should not be bent to exceed 1%. Therefore the variation at 4 meter height should not exceed 4 cm.
- Take necessary precautions towards the weather conditions to work safely

on ProTUBE Scaffolds.

- Take necessary precautions towards the environmental factors to work safely on ProTUBE Scaffolds.
- Use extra safety guardrails when needed for safety and legislation.
- Never leave ProTUBE Scaffolds without someone to take care of it. Prevent unauthorized people to access the scaffold.
- Anchor the working towers if it is unattended.
- It is forbidden to mix scaffold parts of different brands/manufacturers, this mixture may cause a danger for the safety since load and balance calculation is not made for this mixture configuration.
- The working area around ProTUBE Scaffolds should be taken under cords by using pins and/or signing straps.
- You may use lateral feet (supports) when there are significant horizontal loads, though it is not mandatory for under 2.5 m. (It is recommended for safe operation.)
- Ensure the operation of ProTUBE Scaffolds is always prioritized.
- There should be at least 2 people working on ProTUBE Scaffolds at all times (Diagram 5.)

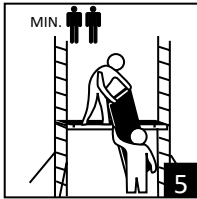

- Do not access to platform from outside. Access to platform from inside use trapdoor to access on the platform

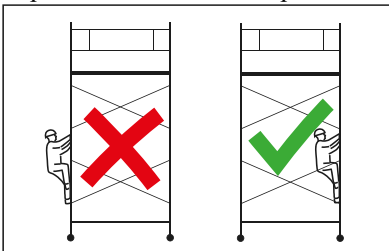

## 2.3 Check List for Usage of ProTUBE Scaffold

In the first usage or reuse of a ProTUBE Scaffold whose installation is completed, the following should be considered:

- The product is suitable for usage with ProTUBE Scaffolds.
- ProTUBE Scaffolds allows safe operation in the immediate vicinity of the assembly point.
- ProTUBE Scaffolds can be used safely.
- Surface is horizontal, straight and can carry necessary load amount.
- Environmental factors such as the opening doors, automatically used sunshades, electricity cables above, traffic and/or the people crossing the road etc. shall not cause danger.
- The area necessary to assemble and use of ProTUBE Scaffolds should be without barriers.
- All necessary parts and security tools are available on the working area.
- Damages parts or parts other than those mentioned shall not be used.
- ProTUBE Scaffolds is assembled in accordance with this handbook and configuration table.
- Maximum installation height is not exceeded.
- ProTUBE Scaffolds is assembled in a way that it can be climbed inside.
- Wheels are correctly placed, aligned and brake is applied.
- Frames are correctly mounted and fixed with pins.
- Horizontal and diagonal braces are correctly mounted and fixed.
- Lateral feet (supports) are correctly mounted.
- ProTUBE Scaffolds is vertical (check by using level).
- ProTUBE Scaffolds is balanced.
- Platforms are corrected in right places and wind security lock is placed.
- There are resting platforms with at least 4 meter distances;
- ProTUBE Scaffolds compounds should be controlled and configuration should be examined in every ins-

tallation.

- All locking pins are on their actual location on the scaffold and are locked.

## 2.4 Examination, Storage and Maintenance

- ProTUBE Scaffolds parts should be carried and transported carefully in order to avoid damages.
- Storage should be organized in a way that it will only contain number of parts necessary for the correct installation of ProTUBE Scaffold.
- All moving parts should be checked for correct operation and it should be ensured that they are not worn.
- All parts should be checked for damages. Damaged or unsuitable parts should not be used.
- Damaged parts should be returned to the manufacturer for examination.
- It is recommended to examine the ProTUBE Scaffolds for professional usage by an expert every year.
- ProTUBE Scaffolds should be examined again before each usage and in emergencies such as a storm.

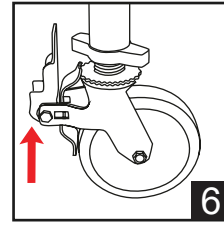

- While moving ProTUBE Scaffolds, there shouldn't be anyone and/or any material on the scaffold and there shouldn't be any missing compound (Diagram 7)

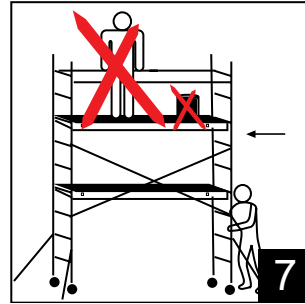

## 2.5 Disassembly of ProTUBE Scaffolds

ProTUBE Scaffolds should be disassembled by following the assembling instructions backwards.

## 2.6 Relocation of ProTUBE Scaffolds

- The height must be decreased to maximum 6 meters in order to move ProTUBE Scaffolds.
- Stabilizers should be lifted maximum 10 cm in order to move ProTUBE Scaffolds.
- Wheeled legs are liberated by lifting the brake pedals. (Diagram 6)

- Environmental factors such as the previously opened doors, windload, shades, automatically used sunshades, electricity cables above, traffic and/or the people crossing the road etc. should be examined while moving ProTUBE Scaffolds in order to prevent danger.
- The place of the ProTUBE Scaffolds should only be changed lengthways or towards cross direction on a surface that carries enough flat, horizontal and enough load manually.
- Ensure that ProTUBE Scaffolds does not tilt while moving.
- Right after moving ProTUBE Scaffolds brake pedal should be pushed and wheeled legs should be engaged and locked.
- After moving scaffold needs to be horizontally aligned again, this should be done by using a level.
- Readjust all stabilizers in a way that

they will all contact with the surface

## 2.7 Assembly and/or Repair of Spare Parts

Take in to account the national regulations for inspections, maintenance and repair of the working towers.

The spare parts provided by Çağsan Merdiven should be assembled on the right product and in the same way as the replaced part.

If assembly (connection) and/or repairs are performed by the customer, risk and expenses shall belong to the customer. Çağsan Merdiven shall not be responsible for damages resulting from wrong assembly and/or repair.

Çağsan Merdiven may provide services for the repair of your product and/or assembly of the said part with payment

## 2.8 Guarantee Conditions

Related Çağsan Merdiven product is designed, manufactured carefully and its necessary quality controls are performed. If this product is used in compliance with this instruction and its usage purpose it shall be under the guarantee with the following conditions:

1. Çağsan Merdiven guarantees the reliability of the product and the quality of the materials used for the product.
2. If there is a fault in production, the faulty part or the product is replaced under the guarantee scope and the problem is solved.
3. The faults that are not covered with the guarantee are those stated below:
  - a) Usage of product in violation of usage purpose and usage instructions.
  - b) Normal wear and tear of the product.
  - c) Assembly or repair performed by the customer or third parties (the replacement of spare parts provided by Çağsan Merdiven as shown in the 2nd article above is excluded).
4. The faults determined during product delivery should be immediately informed to Çağsan Merdiven. If these

faults are not immediately informed the guarantee shall be void. In order to make a request under the guarantee scope, Çağsan Merdiven or Çağsan Merdiven dealer should be informed about the product delivery and an invoice should be submitted.

5. Product faults should be informed to Çağsan Merdiven or Çağsan Merdiven dealer as soon as possible but within 7 days after the determination of the fault at the latest.
6. a) If a request is made under the guarantee conditions, Çağsan Merdiven product shall be examined by Quality Department. Customer needs to deliver the product to Çağsan Merdiven for this purpose. If during the examination it is determined that the product was inappropriately used, examination expenses shall be requested from the customer.
  - b) If customer requests the examination to be made by an independent organization and if as a result of the examination it is determined that the product was used inappropriately, examination expenses shall be covered by the customer. Even if Çağsan Merdiven requested a free repair or replacement of the product before the examination, the expenses shall belong to the customer again.

## 2.9 Fastening of Frames

Fix the frames with locking pins.  
(Diagram 8 - 9)

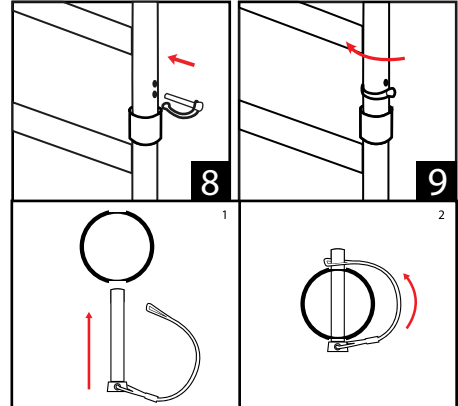

## 2.10 Locking the Wheels

You need to push the brake pedal in order to lock the wheels. You need to lift the brake pedal in order to unlock the wheels. (Diagram 10 - 11)

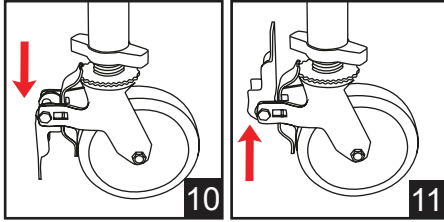

- Check the condition of the wood.
- Check the trapdoors for correct functioning.

### Toeboards

- Check the condition of the wood.
- Check the toeboards for cracking.

### Castors

- Check the castor for smooth running and check that the brake stops the castor rolling or twisting.
- In the case of swivel castors with height adjusters, also check that the height adjusters move easily.
- Check the drop-out protection (wing bolt, securing plug) on the chassis beams and base frame.

### Locking Pins

- Check for warping, crushing, cracks and correct seating.

### Stabilizer

- Check for warping, crushing, cracks and correct seating.

## 2.11 Balancing of the Scaffold

You need to turn the screwed tool right and left in order to balance your scaffold. Tool moves upwards-downwards on the gears and heightens and lowers your scaffold. (Diagram 12 - 13)

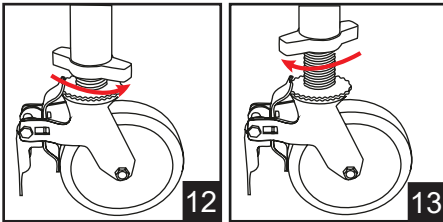

## Check List

If defects are ascertained, the affected components must not be used again.

### Frame and Braces

- Check for warping, crushing and cracks.
- Braces (diagonal / railings)
- Check for warping, crushing, cracks and correct functioning of the fastening elements.

### Platforms

- Check for warping, crushing, cracks and correct functioning of the fastening elements.



# 3. ProTUBE L (Wide) Aluminum Scaffold System

## 3.1 ProTUBE L Configuration Table

			L4	L6	L8	L10	L12	L14
Platform Height (m.)			2,30	4,40	6,50	8,00	10,70	12,20
Working Height (m.)			4,10	6,20	8,30	9,80	12,50	14,00

120x240 cm.	Explanations	Item Code	Weight (kg.)	Piece					
	Modular Frame 7 Steps	PT223M	9,32	2	4	6	6	10	10
	Modular Frame 5 Steps	PT263M	6,82	-	-	-	2	-	2
	Guardrail Frame	PT110K	3,44	2	2	2	2	2	2
	Platform (With Trapdoor)	PT258KP	23,14	1	1	2	2	3	3
	Platform (Without Trapdoor)	PT258K	23,11	1	1	2	2	3	3
	Diagonal Braces	PT275C	2,23	4	8	12	16	20	24
	Guardrail Braces (H)	PT259H	4,9	2	2	2	2	2	2
	Horizontal Braces	PT259Y	2,13	2	2	8	8	14	14
	Stabilizer	PT276PA	4,04	-	4	4	4	4	4
	Castor	PT200TE	5,5	4	4	4	4	4	4
	Toeboard	PT302TM	16,17	1	1	2	2	3	3
<b>Total Weight</b>			<b>133</b>	<b>177</b>	<b>279</b>	<b>302</b>	<b>410</b>	<b>432</b>	

120x240 cm.	Explanation	Item Code	Measurements
	Modular Frame 7 Steps	PT223M	1355x2225x50 mm.
	Modular Frame 5 Steps	PT263M	1355x1625x50 mm.
	Guardrail Frame	PT110K	1355x1100x50 mm.
	Platform (With Trapdoor)	PT258KP	2575x600x80 mm.
	Platform (Without Trapdoor)	PT258K	2575x600x80 mm.
	Diagonal Braces	PT275C	2750x50 mm.
	Guardrail Braces (H)	PT259H	2590x535x50 mm.
	Horizontal Braces	PT259Y	2590x50 mm.
	Stabilizer	PT276PA	2850x110x50 mm.
	Castor	PT200TE	740x200x80 mm.
Toeboard	PT302TM	2390x100x200 mm.	

### 3.2 ProTUBE L6 Scaffold Assembly Method

1. Place the castors to the seats in the modular frames. (Diagram 1)

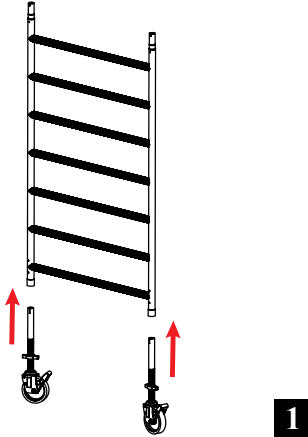

2. Straighten the 2 modular frames whose castors you have placed and lock the castors. (Diagram 2) Place the 2 horizontal braces onto the 1st step and fasten it to the modular frame from the interior part. Make sure the aluminum cast clamps on the corners of the connections are safely seated and locked. (Diagram 3)

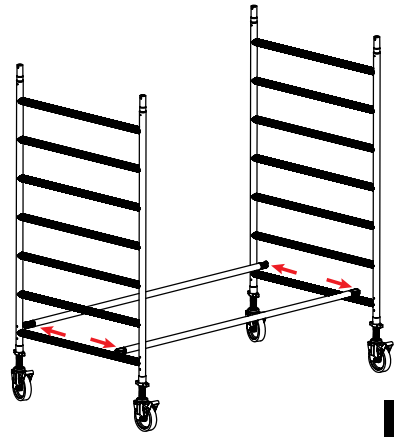
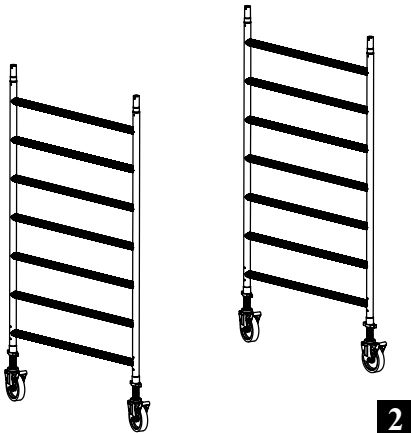

3. Place 2 diagonal braces reciprocally between the 2nd steps and 5th steps of the modular frame. Make sure the aluminum cast clamps on the corners of the connections are safely seated and locked. (Diagram 4)

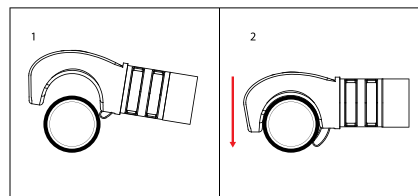
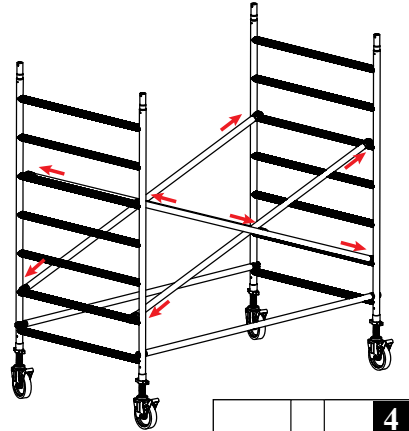

4. Then place the 1 covered platform to the 3rd step. Balance the scaffold according to the long sides and short sides by using a water scale. (Diagram 5) You need to turn the screwed tool on the wheels right and left in order to balance your scaffold.

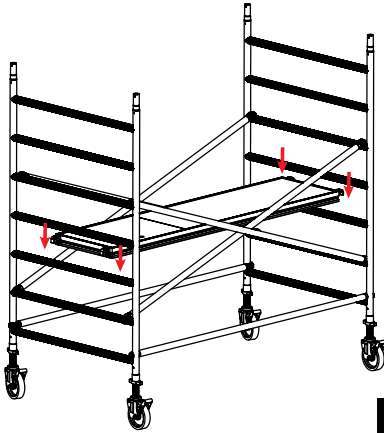

5

5. Fix 4 balance legs (support) to the scaffold. Connect the connection tool between the short part of the balance legs to the gap between 2nd step and 3rd step and its long part to the gap between 6th step and 7th step. After making sure the tools completely grasp the carrier profile, tighten the bakalite heads by turning. Make sure each balance leg wedges are in contact with the solid surface (Diagram 6 and 7). It is not mandatory to use balance legs for working heights lower than 2.5 m. However if the work applies a horizontal load on the scaffold, balance legs should be used.

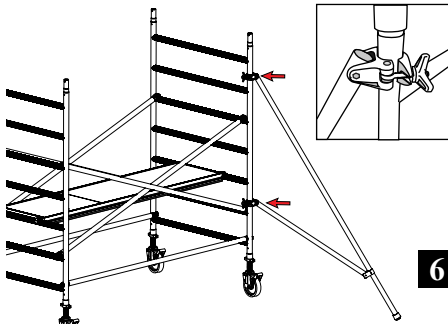

6

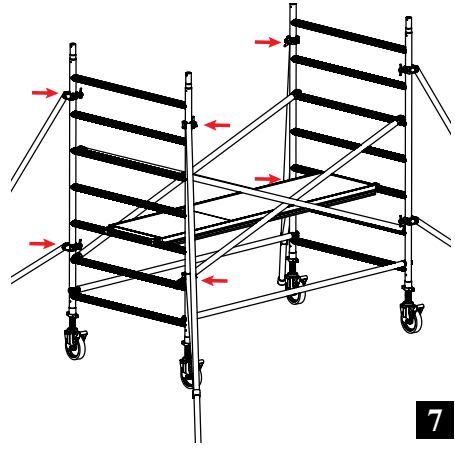

7

6. Go on top of the platform of the 3rd step. Place the modular frames of the 2nd floor by passing through the modular frames of the 1st floor. Pass the security pins from the holes of the modular frames and lock it. (Diagram 8)

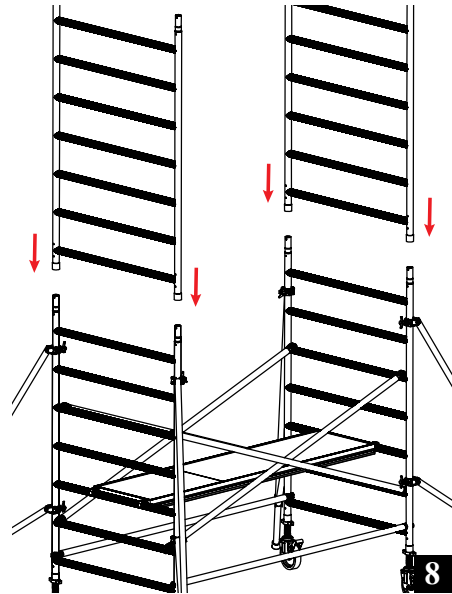

8

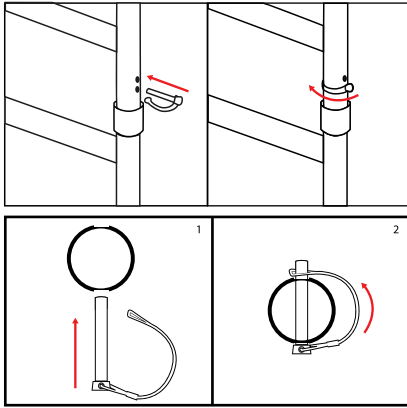

7. Place the 4 cross connection parts to the modular frames you just placed. Make sure the aluminum cast clamps are safely seated and locked. (Diagram 9)

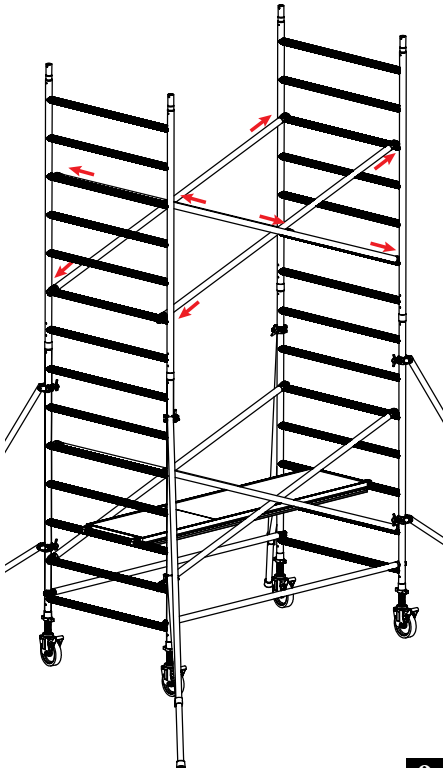

9

8. Then place the platform without trap-door in line with the 3rd step of the 2nd floor while you are on the 1st floor. After this process your scaffold will rise for another floor. (Diagram 10)

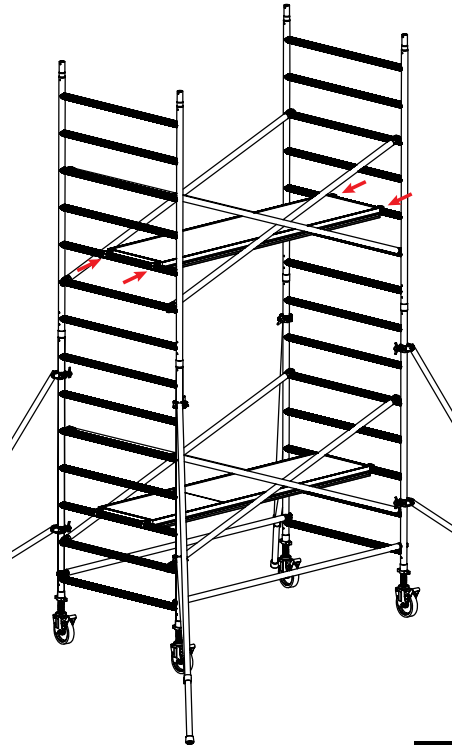

10

9. Get on top of the platform you placed on the 2nd floor and put the guardrail frames into the fitting tool of the modular frames of the 2nd floor. Pass the security pint of the guardrail frames from the holes of the modular frames and lock them. (Diagram 11)

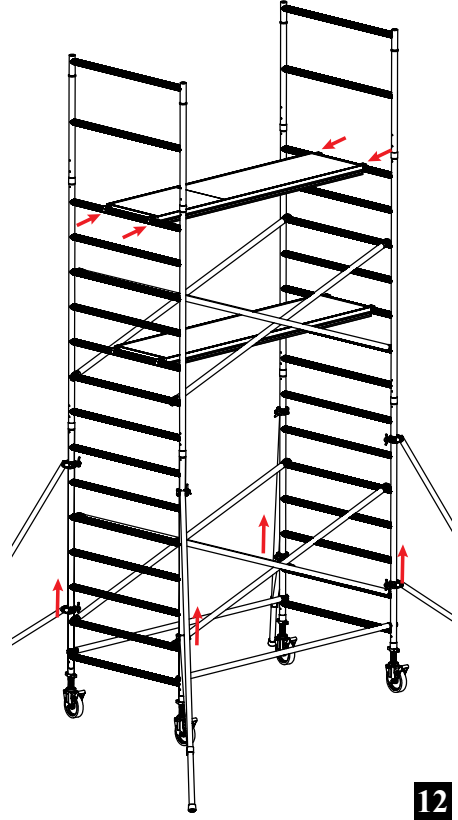
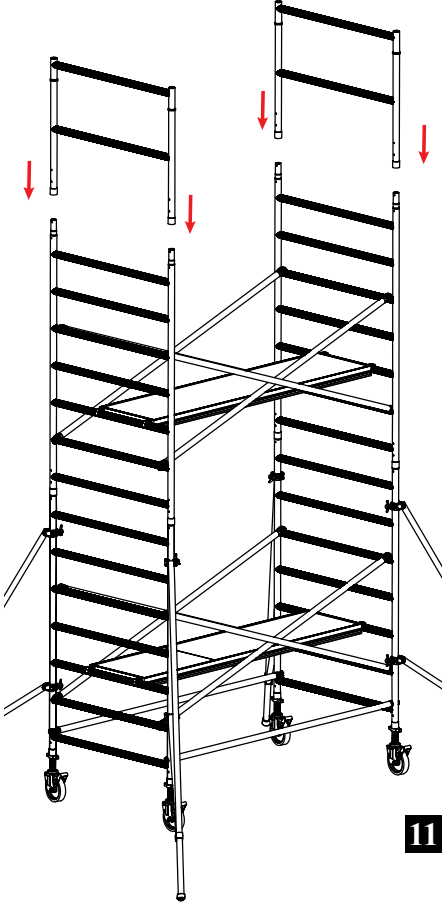

10. Get on top of the platform with trap-door on the 1st floor and carry the modular frame of the 2nd floor to the 7th step. (Diagram 12) Don't forget to open the wind lock while disassembling the platforms.

11. Pass through the platform by lifting the trapdoor of the platform with the trapdoor you placed on top and sit at the corner. Fix the horizontal security connections of the guardrail. Make sure the aluminum cast clamps are safely seated and locked. (Diagram 13)

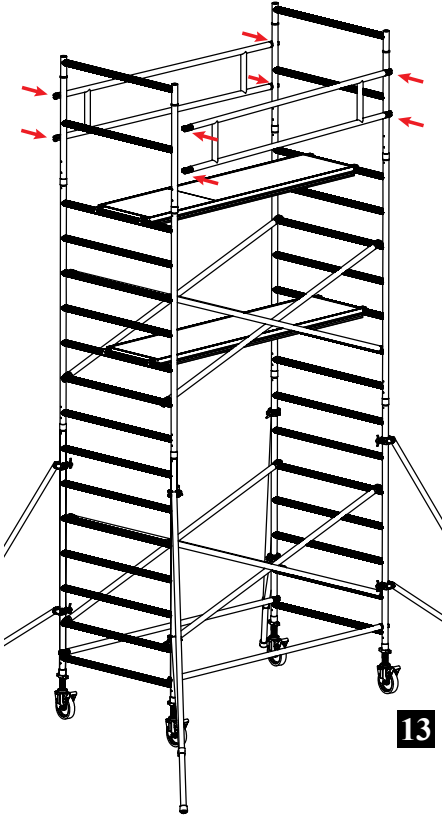

13

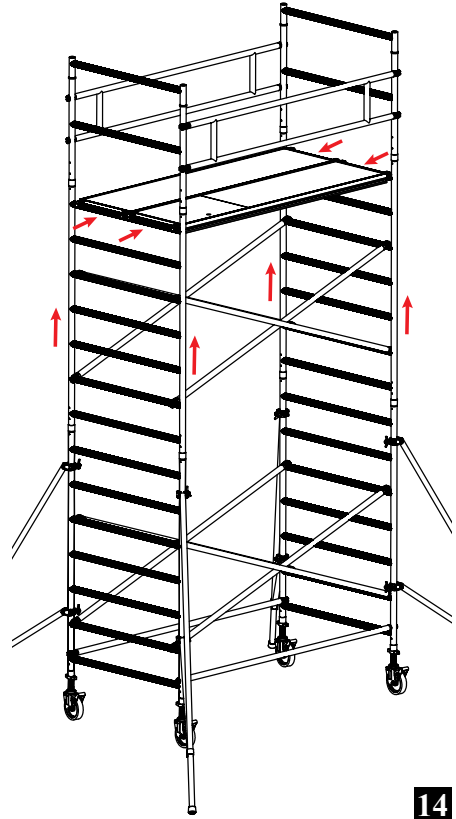

14

12. Place the platform you assembled on top to the corner by getting into the lower platform. Remove the platform without trapdoor on the 2nd floor on which you are standing and carry it near this platform. (Diagram 14)

13. Place the wooden pad in a way that it will surround the 2 platforms at the top. (Diagram 15)

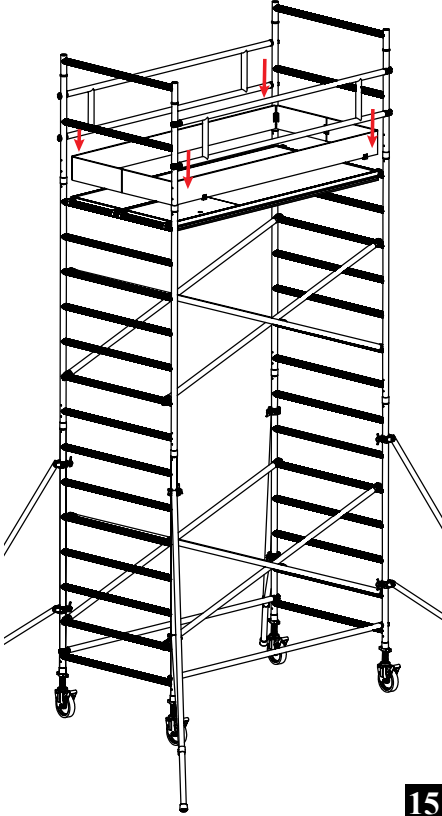

15

14. Your ProTUBE L6 coded product with 4.40 m. stepping height is ready for usage. (Diagram 16)

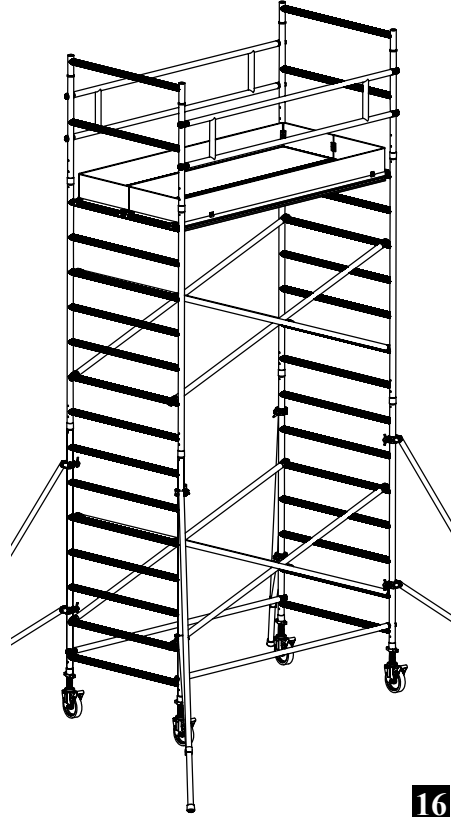

16

You need to repeat the steps 6-7-8 in order to increase the height of your scaffold.

The height of the first platform should be maximum 4.60 m and the distance between the platforms should be maximum 4.20 m.

While changing the height, act in accordance with the configuration tables and technical diagrams.

Thank you for choosing Çağsan Merdiven products.

### 3.3 ProTUBE L (Wide) Aluminum Scaffold System 3D Pictures

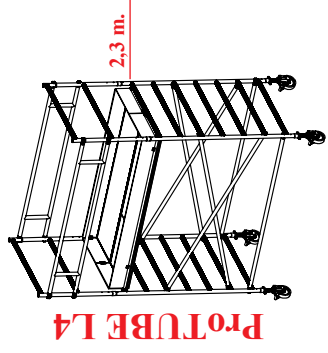
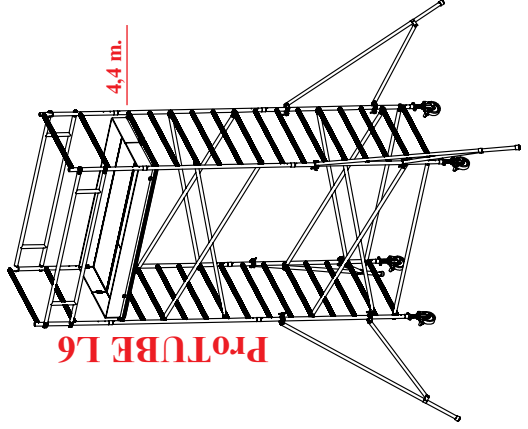
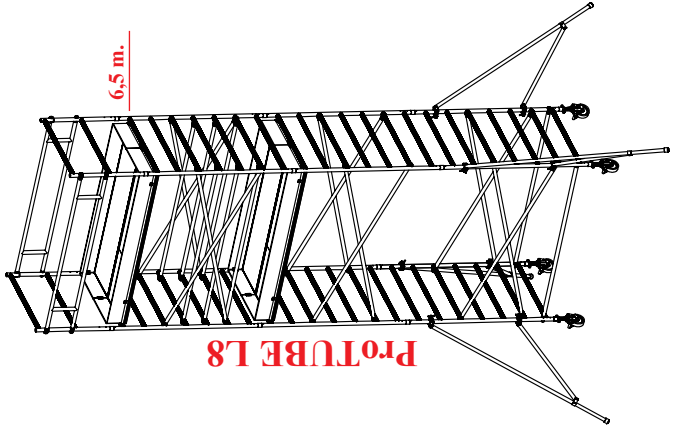



### 3.3 ProTUBE L (Wide) Aluminum Scaffold System 3D Pictures

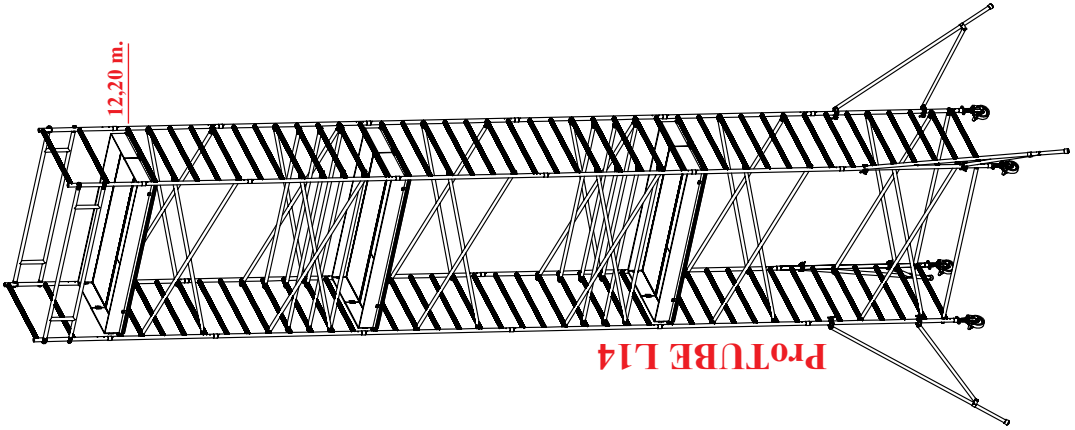
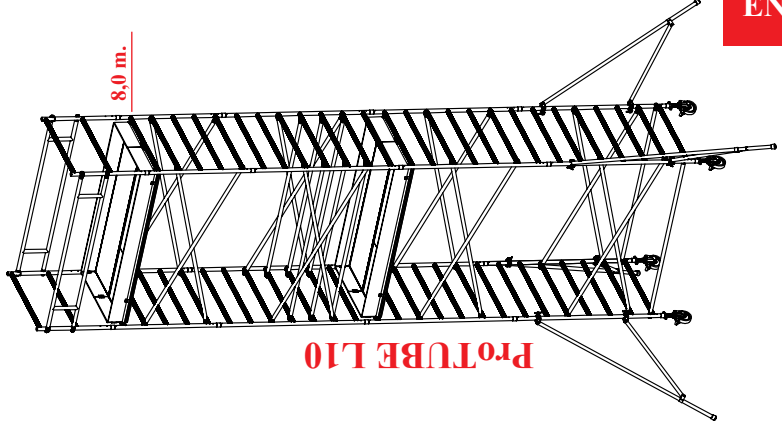
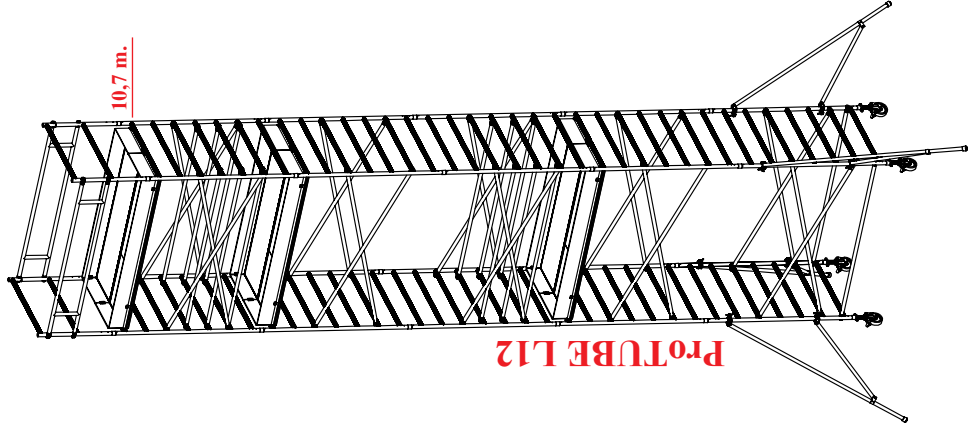

### 3.4 ProTUBE L Scaffold System Compounds

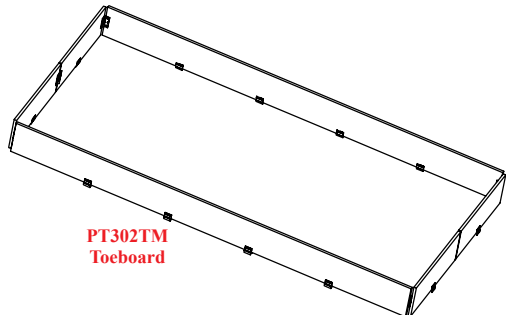
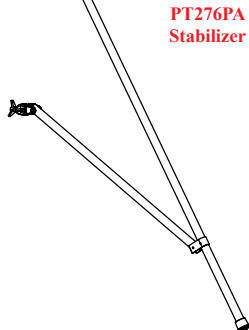
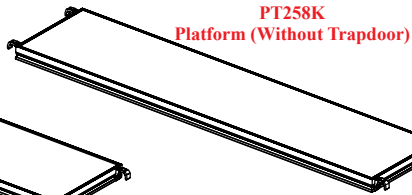
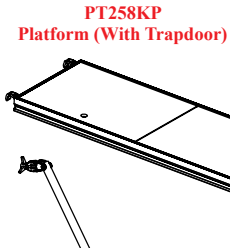
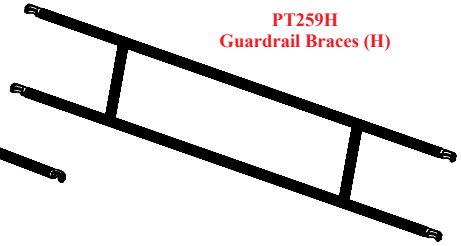
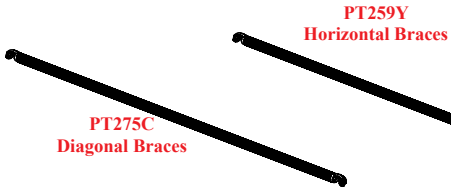
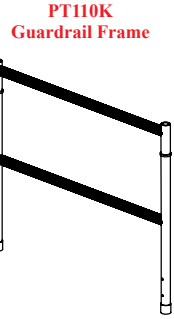
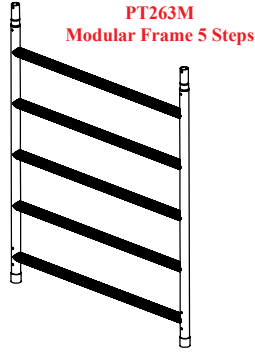
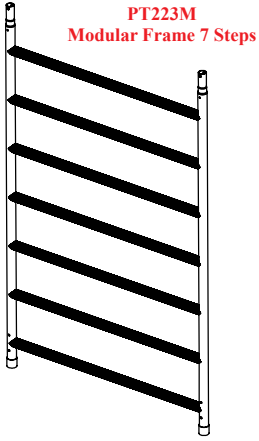

## 4. ProTUBE S (Narrow) Aluminum Scaffold System

### 4.1 ProTUBE S Configuration Table

			S4	S6	S8
Platform Height (m.)			2,30	4,40	6,50
Working Height (m.)			4,10	6,20	8,30

60x240 cm.	Explanation	Item Code	Weight (kg.)	Qty		
	Modular Frame 7 Steps	PTS223M	9,0	2	4	6
	Guardrail Frame	PTS110K	3,5	2	2	2
	Platform (With Trapdoor)	PT258KP	23,5	1	1	2
	Diagonal Braces	PT275C	2,2	4	8	12
	Guardrail Braces (H)	PT259H	4,0	2	2	2
	Horizontal Braces	PT259Y	2,0	2	2	2
	Stabilizer	PT276PA	4,0	-	4	4
	Castor	PT200TE	5,5	4	4	4
	Toeboard	PTS302TM	11,0	1	1	2
<b>Total Weight</b>			<b>102,3</b>	<b>145,1</b>	<b>206,4</b>	

60x240 cm.	Explanation	Item Code	Measurements
	Modular Frame 7 Steps	PTS223M	735x2225x50 mm.
	Guardrail Frame	PTS110K	735x1100x50 mm.
	Platform (With Trapdoor)	PT258KP	2575x600x80 mm.
	Diagonal Braces	PT275C	2750x50 mm.
	Guardrail Braces (H)	PT259H	2590x535x50 mm.
	Horizontal Braces	PT259Y	2590x50 mm.
	Stabilizer	PT276PA	2850x110x50 mm.
	Castor	PT200TE	740x200x80 mm.
	Toeboard	PTS302TM	2970x50x200 mm.

## 4.2 ProTUBE S6 Scaffold Assembly Method

1. Place the wheeled legs to the seats in the modular frames. (Drawing 1)

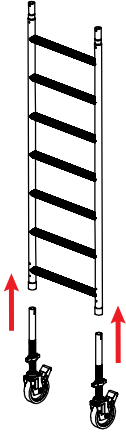

1

2. Straighten the 2 modular frames whose wheels you have placed and lock the wheels (Drawing 2). Place the 2 horizontal braces onto the 1st step and fasten it to the modular frame from the interior part. Make sure the aluminum cast clamps on the corners of the connections are safely seated and locked (Drawing 3).

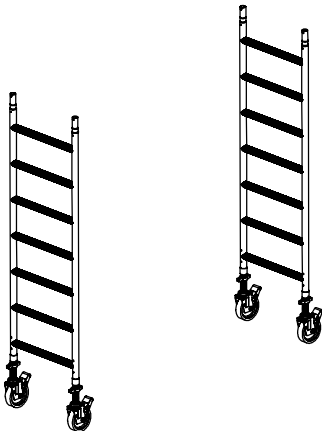

2

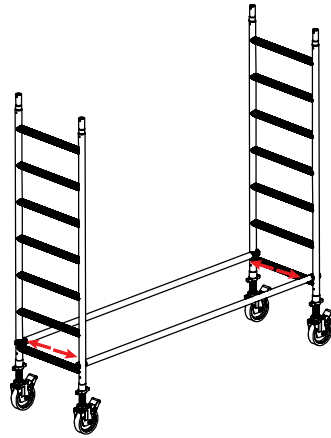

3

3. Place 2 diagonal braces reciprocally between the 2nd steps and 5th steps of the modular frame. Make sure the aluminum cast clamps on the corners of the connections are safely seated and locked (Drawing 4).

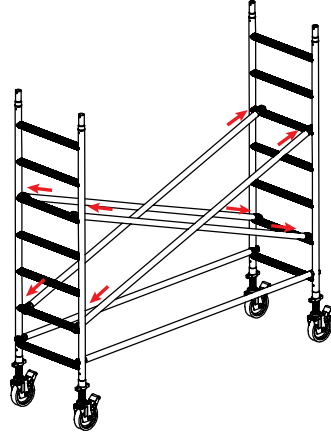

4

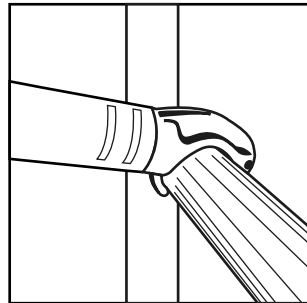

4. Fix 4 balance legs (support) to the scaffold. Connect the connection tool between the short part of the balance legs to the gap between 2nd step and 3rd step and 3rd step and its long part to the gap between 6th step and 7th step. After making sure the tools completely grasp the carrier profile, tighten the bakelite heads by turning. Make sure each balance leg wedges are in contact with the solid surface. Then place the 1 covered platform to the 7th step. Balance the scaffold according to the long sides and short sides by using water scale (Drawing 6 and 7).

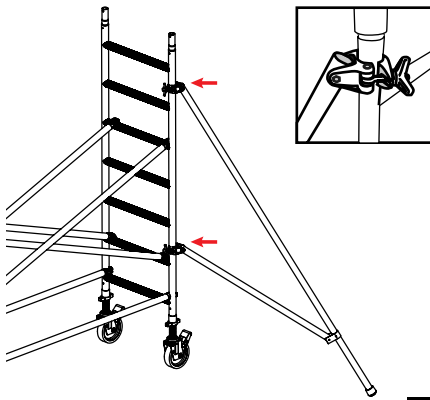

6

It is not mandatory to use balance legs for working heights lower than 2.5 m. However if the work applies a horizontal load on the scaffold, balance legs should be used

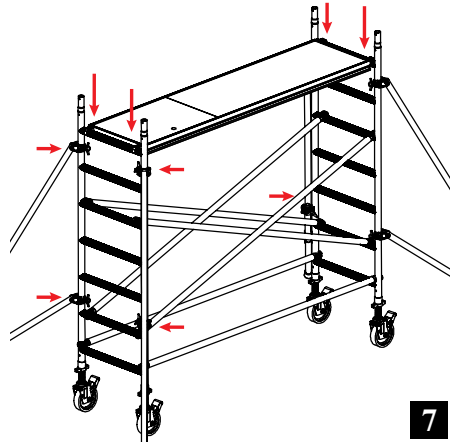

7

5. Go on top of the platform of the 7th step. Place the modular frames of the 2nd floor by passing through the modular frames of the 1st floor. Pass the security pins from the holes of the modular frames and lock it (Drawing 8).

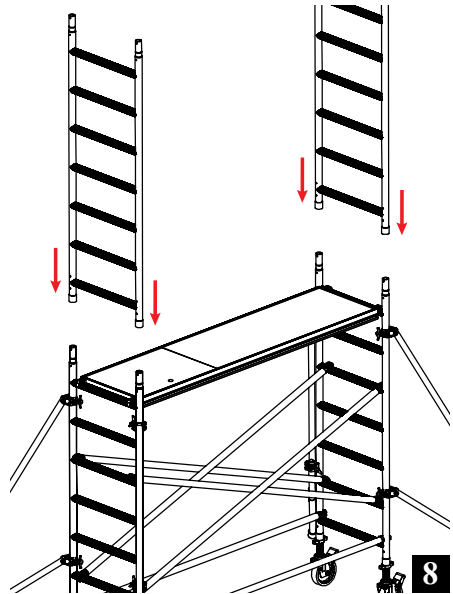

8

6. Place the 4 cross connection parts to the modular frames you just placed. Make sure the aluminum cast clamps are safely seated and locked. (Drawing 9)

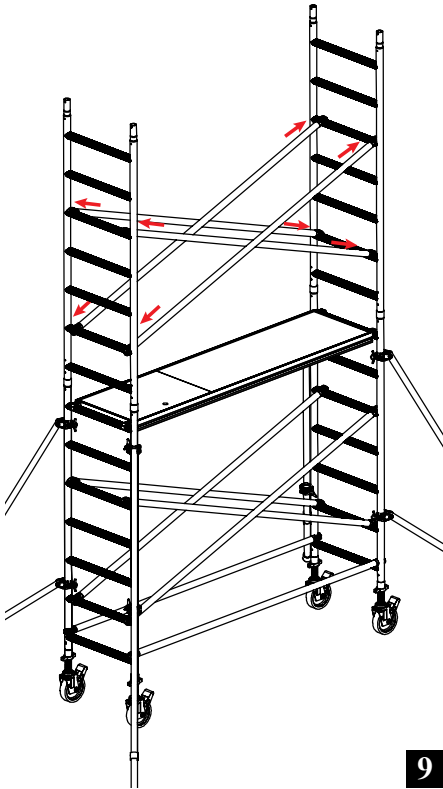

9

7. Then carry it upwards onto the 7th step of the 2nd floor and fix it. Don't forget to open the wind lock while disassembling the platforms. After this your scaffold will rise for another floor (Drawing 10)

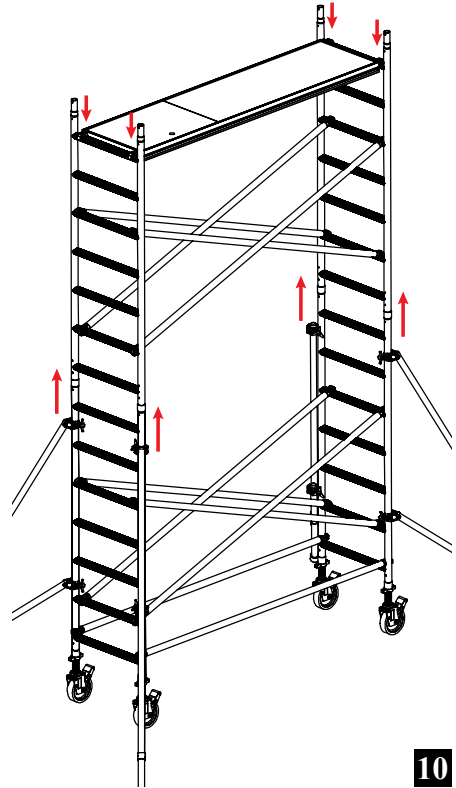

10

8. Get on top of the platform you placed on the 2nd floor and put the guardrail frames into the fitting tool of the modular frames of the 2nd floor. Pass the security pint of the guardrail frames from the holes of the modular frames and lock them (Drawing 11).

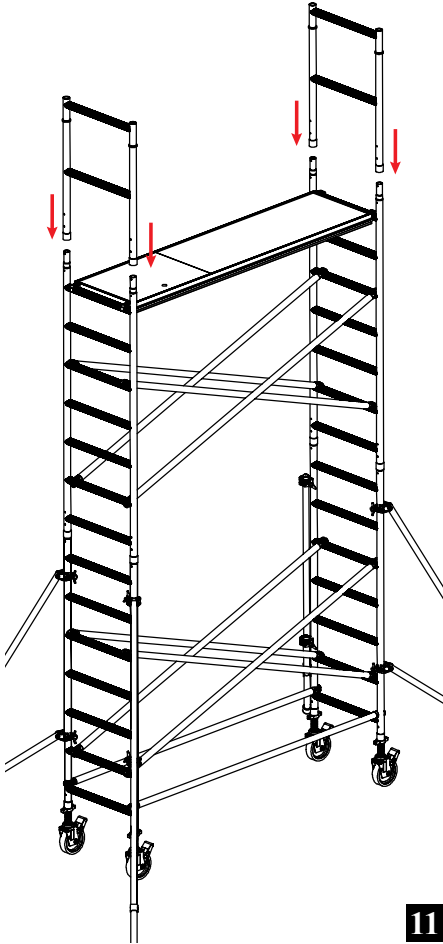

9. Fix the horizontal security connections of the guardrail. Make sure the aluminum cast clamps are safely seated and locked (Drawing 12).

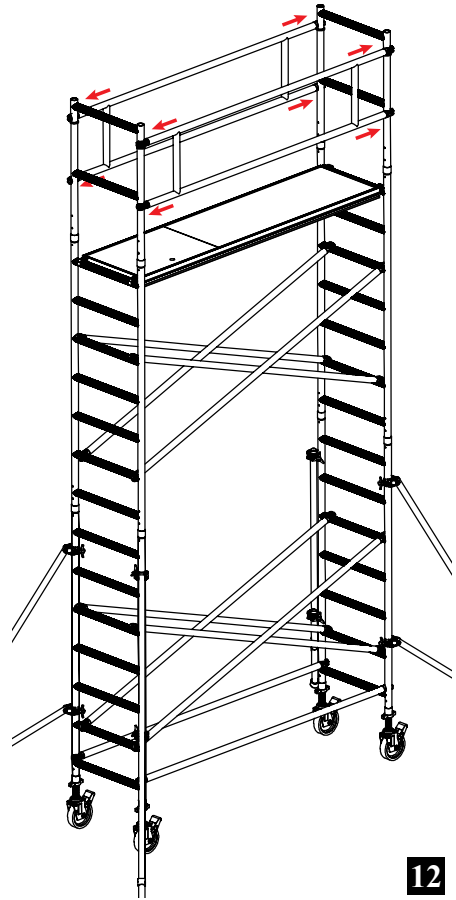

10. Place the wooden pad in a way that it will surround the platform at the top (Drawing 13).

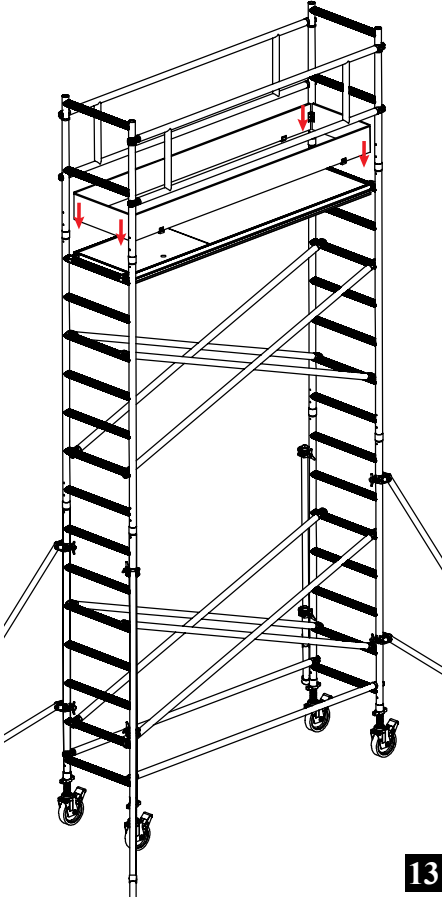

13

11. Your ProTUBE F6 coded product with 4.40 m. stepping height is ready for usage (Drawing 14)

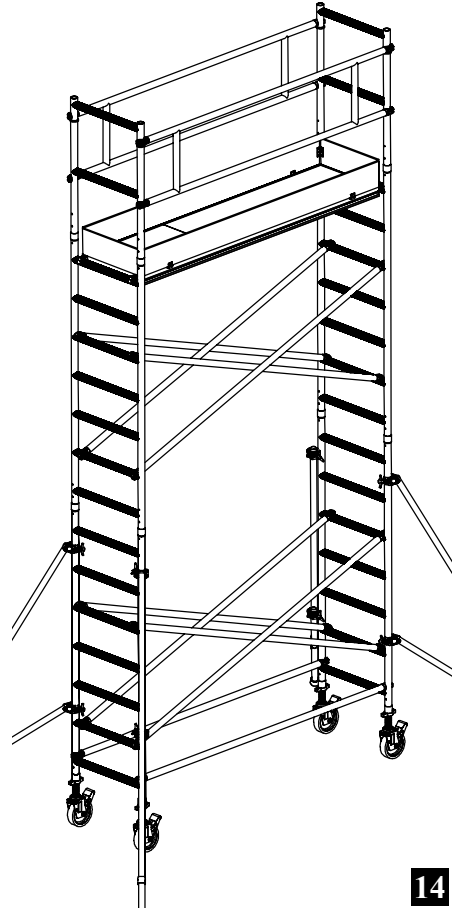

14

You need to repeat the steps 5-6-7 in order to increase the height of your scaffold.

The height of the first platform should be maximum 4.60 m and the distance between the platforms should be maximum 4.20 m

While changing the height, act in accordance with the configuration tables and technical diagrams.

Thank you for choosing Çağsan Merdiven products..



### 4.3 ProTUBE S (Narrow) Aluminum Scaffold System 3D Ima-

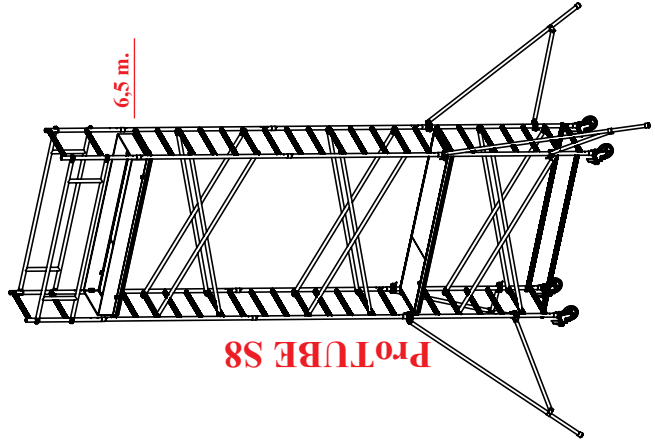
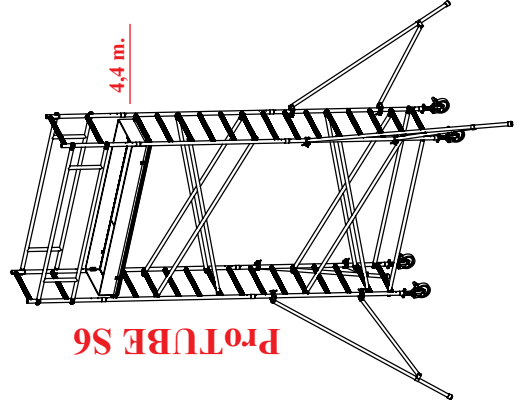
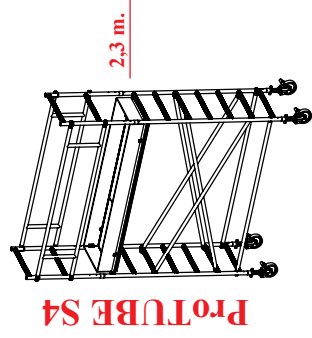

## 4.4 ProTUBE S Scaffold Systems Compounds

**PTS223M**  
Modular Frame 7 Steps

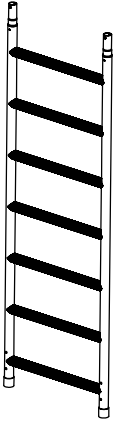

**PTS110K**  
Guardrail Frame

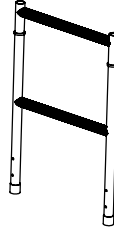

**PT259Y**  
Horizontal Braces



**PT259H**  
Guardrail Braces (H)

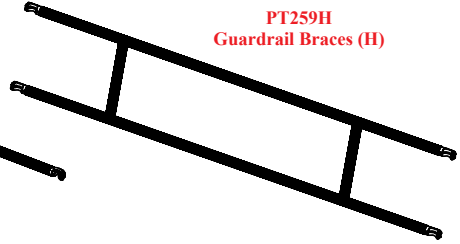

**PT275C**  
Diagonal Braces



**PT258KP**  
Platform (With Trapdoor)

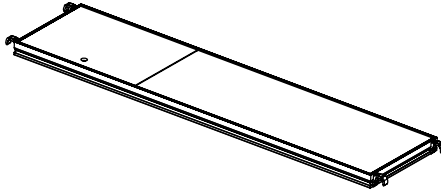

**PT200TE**  
Castor

**PT276PA**  
Stabilizer

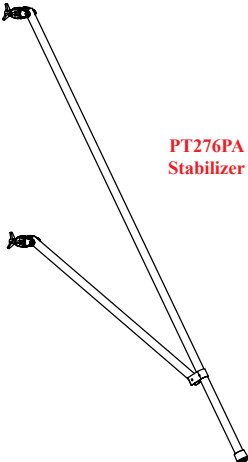

**PTS302TM**  
Toeboard

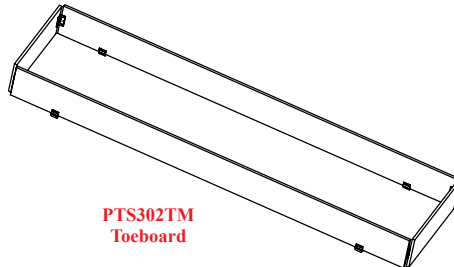

# 5. ProTUBE F Karelia Aluminum Scaffold System

## 5.1 ProTUBE F Configuration Table

			F90	F180	F360
	Platform Height (m.)		0,90	1,80	3,60
	Working Height (m.)		2,70	3,60	5,40

60x180 cm.	Explanation	Item Code	Weight	Qty		
	Foldable Modular Frame	PTF223M	23,0	1	1	1
	Modular Frame 6 Steps	PTF223ME	9,0	-	-	2
	Guardrail Frame	PTS110K	3,5	-	2	2
	Platform (With Trapdoor)	PTF183KP	18,5	1	1	1
	Diagonal Braces	PTF202C	2,2	-	1	5
	Guardrail Braces (H)	PTF182H	4,0	-	2	2
	Horizontal Braces	PTF182Y	2,0	-	1	1
	Stabilizer	PT276PA	4,0	-	-	4
	Castor	PT125TE	5,5	4	4	4
	Toeboard	PTF180TM	11,0	-	1	1
<b>Total Weight</b>			<b>54,5</b>	<b>93,7</b>	<b>136,5</b>	

60x180 cm.	Explanation	Item Code	Measurements
	Foldable Modular Frame	PTF223M	735x1925x156 mm.
	Modular Frame 6 Steps	PTF223ME	735x1800x55 mm.
	Guardrail Frame	PTS110K	735x1100x55 mm.
	Platform (With Trapdoor)	PTF183KP	1982x600x80 mm.
	Diagonal Braces	PTF202C	2200x50 mm.
	Guardrail Braces (H)	PTF182H	2000x535x50 mm.
	Horizontal Braces	PTF182Y	1998x50 mm.
	Stabilizer	PT276PA	2850x110x50 mm.
	Castor	PT125TE	125x80x155 mm.
Toeboard	PTF180TM	2405x200x40 mm.	

## 5.2 ProTUBE F Scaffold Assembly Method

1. Place the wheeled legs to the seats in the modular frames (Drawing 1)

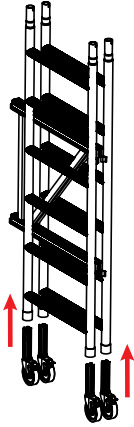

1

2. Open the lock in the middle of the foldable modular frame whose wheels you just put. Take the module to the usable position by opening it outwards and lock it again (Drawing 2-3)

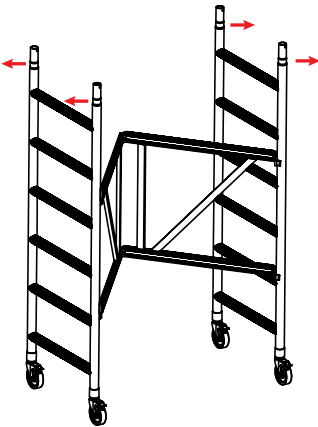

2

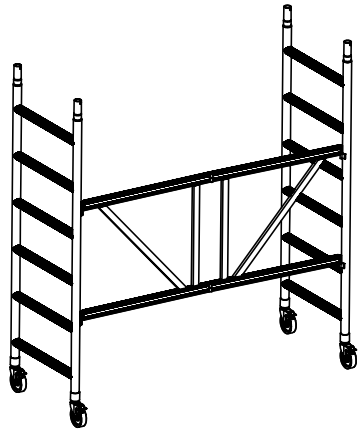

3

3. Place the 1 horizontal connection onto the 1st step and fasten it to the modular frame from the interior part. Fix 2 diagonal braces between the 2nd step to 5th step. Make sure the aluminium cast clamps on the corners of the connections are safely seated and locked (Drawing 4)

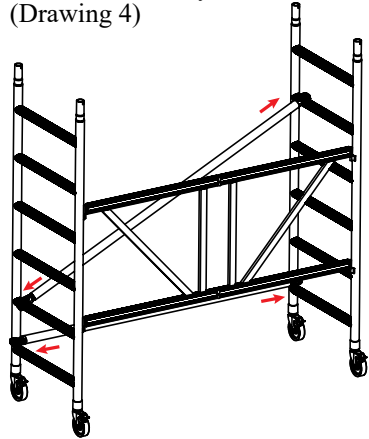

4

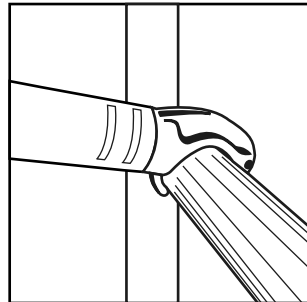

4. Then place the 1 covered platform to the 7th step. Balance the scaffold according to the long sides and short sides by using water scale (Drawing 5)

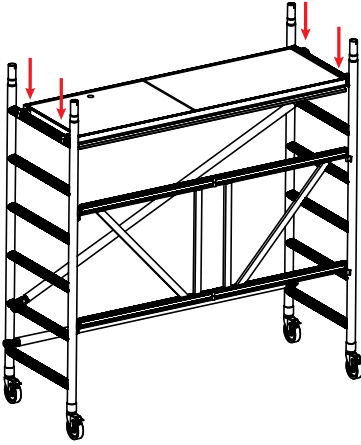

5. Go on top of the platform of the 6th step. Place the modular frames of the 2nd floor by passing through the modular frames of the 1st floor. Pass the security pins from the holes of the modular frames and lock it (Drawing 6)

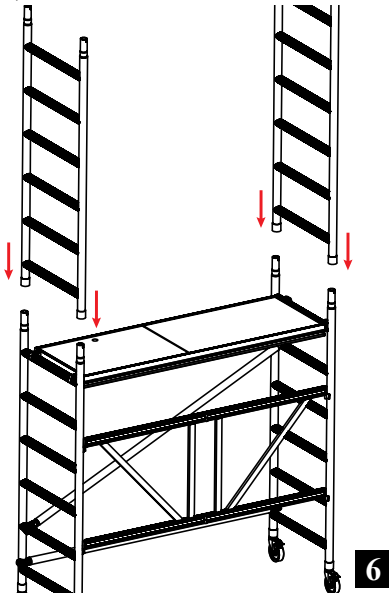

6. Fix 4 balance legs (support) to the scaffold. Connect the connection tool between the short part of the balance legs to the gap between 1st step and 2nd step and its long part to the gap between 6th step and 7th step. After making sure the tools completely grasp the carrier profile, tighten the bakalite heads by turning. Make sure each balance leg wedges are in contact with the solid surface. (Drawing 7)

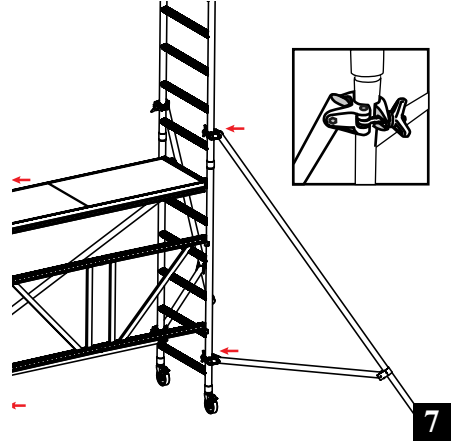

It is not mandatory to use balance legs for working heights lower than 2.5 m. However if the work applies a horizontal load on the scaffold, balance legs should be used.

7. Place the 4 cross connection parts to the modular frames you just placed. Make sure the aluminum cast clamps are safely seated and locked. (Drawing 8)

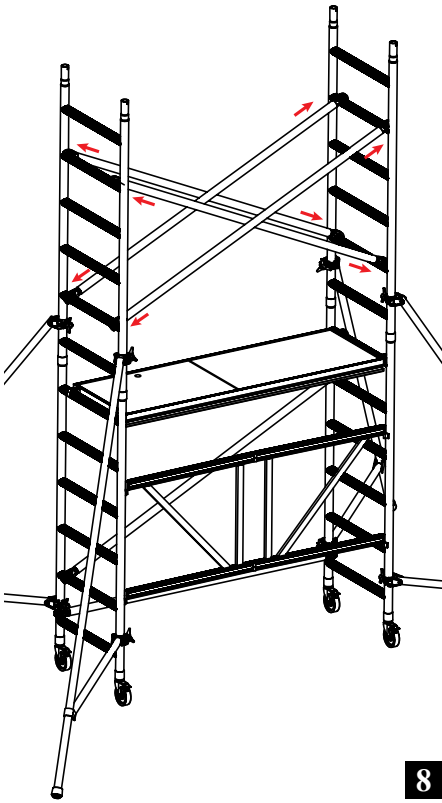

8

8. Then carry it upwards onto the 7th step of the 2nd floor and fix it. Don't forget to open the wind lock while disassembling the platforms. After this your scaffold will rise for another floor (Drawing 9)

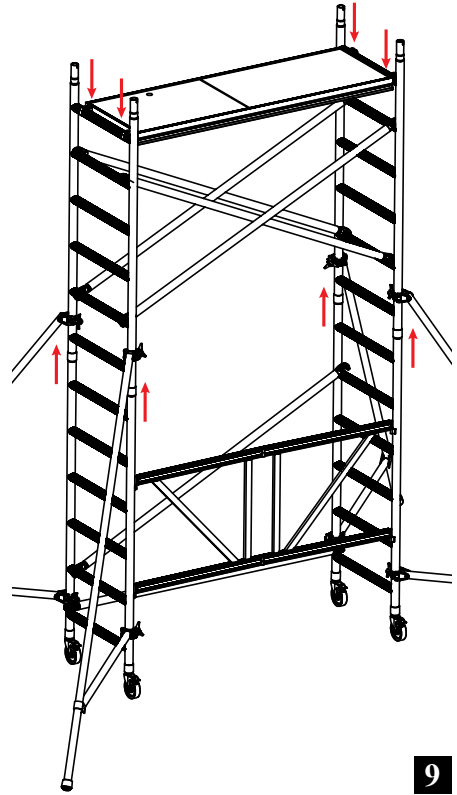

9

9. Get on top of the platform you placed on the 2nd floor and put the guardrail frames into the fitting tool of the modular frames of the 2nd floor. Pass the security pint of the guardrail frames from the holes of the modular frames and lock them (Drawing 10)

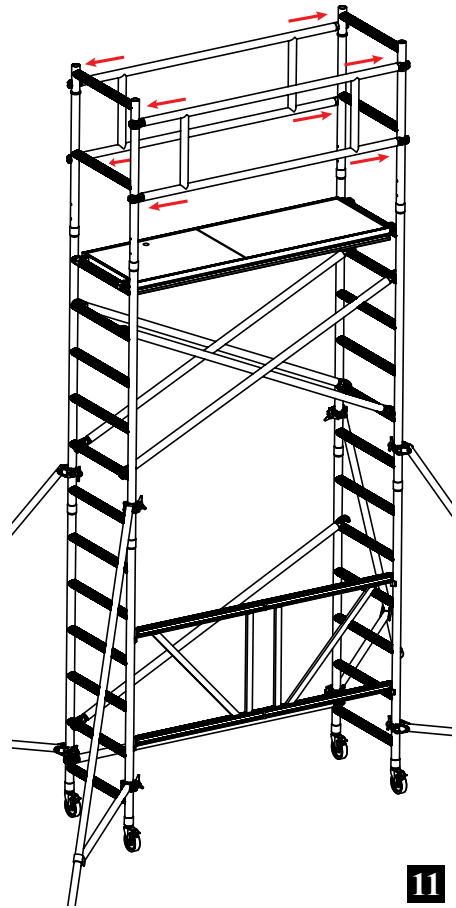
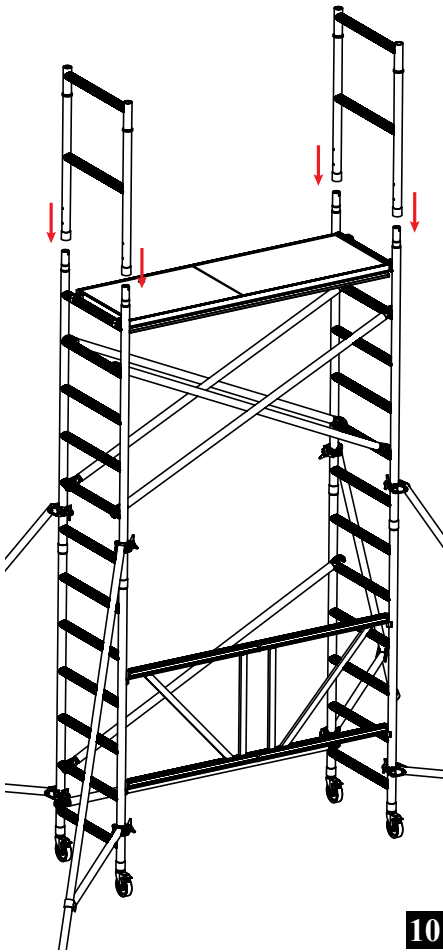

10. Fix the horizontal security connections of the guardrail. Make sure the aluminum cast clamps are safely seated and locked (Drawing 11)

11. Place the wooden pad in a way that it will surround the platform at the top (Drawing 12)

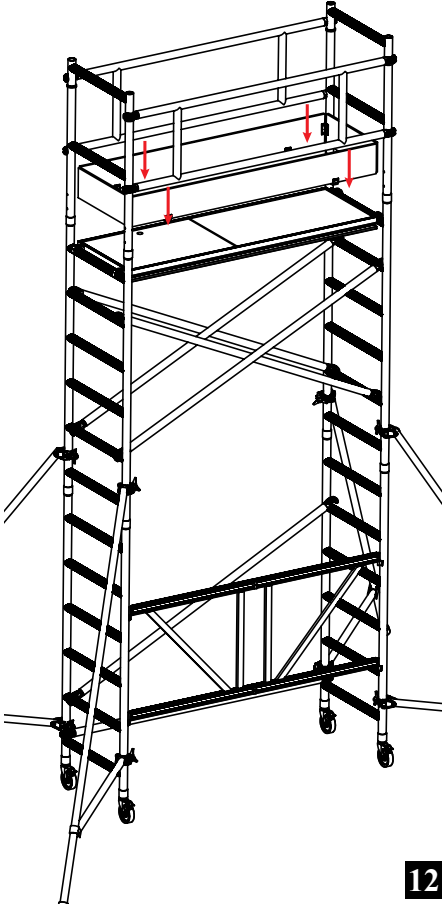

**12**

12. Your ProTUBE F360 coded product with 4.40 m. stepping height is ready for usage (Drawing 13)

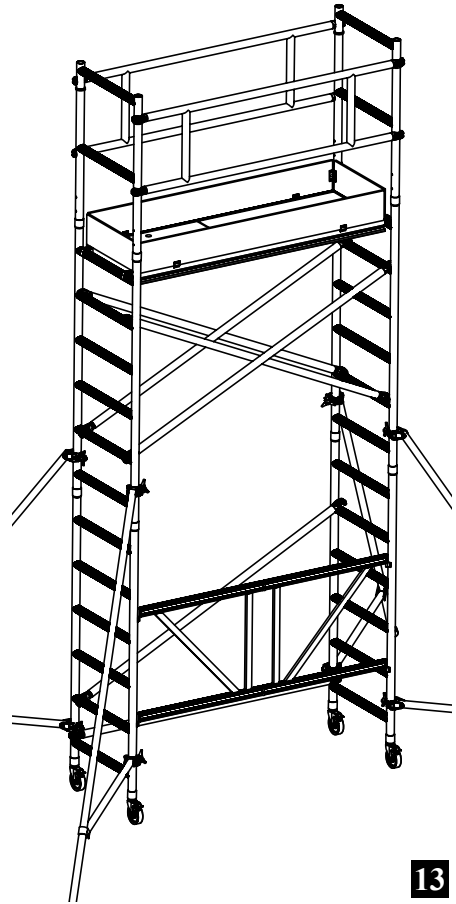

**13**

Thank you for choosing Çağsan Merdiven products.



### 5.3 ProTUBE F (Karelia) Aluminum Scaffold System 3D Images

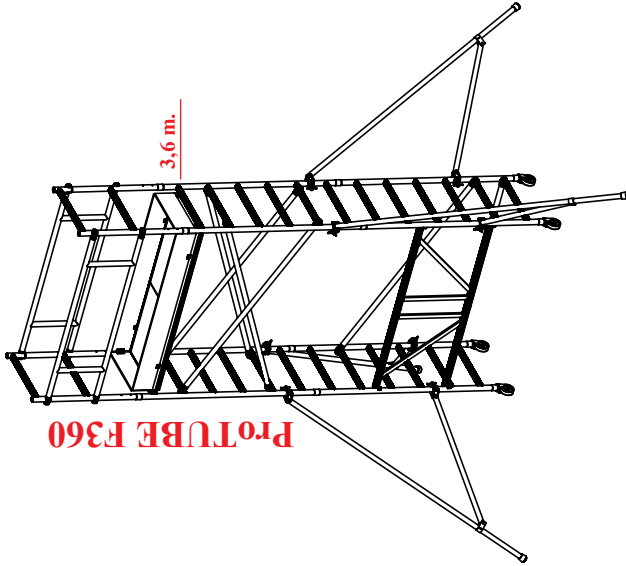
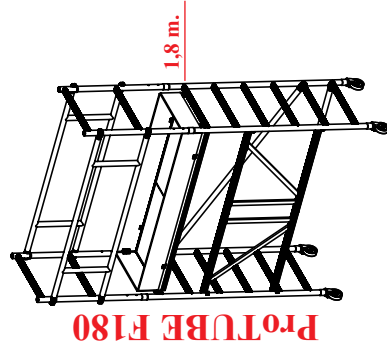
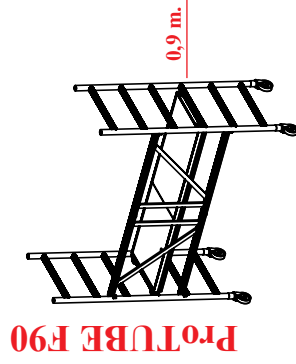

## 5.4 ProTUBE F Karelia Scaffold Systems Compounds

**PTS223M**  
Modular Frame 6 Steps

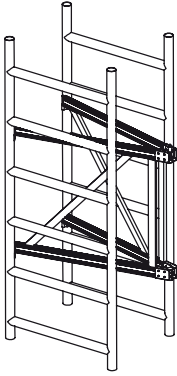

**PTS223ME**  
Modular Frame 6 Steps

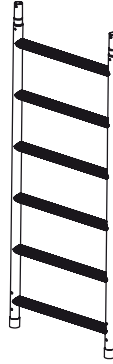

**PTS110K**  
Guardrail Frame

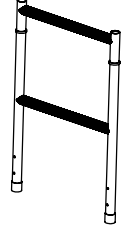

**PTF182Y**  
Horizontal Braces



**PTF182H**  
Guardrail Braces (H)

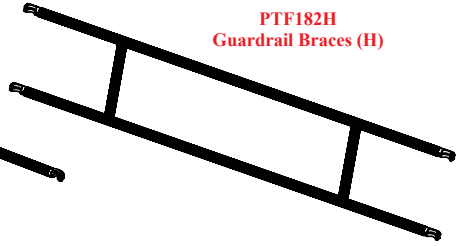

**PTF202C**  
Diagonal Braces



**PTF183KP**  
Platform (With Trapdoor)

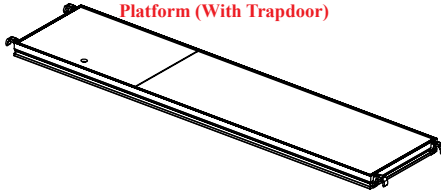

**PT125TE**  
Castor



**PT276PA**  
Stabilizer

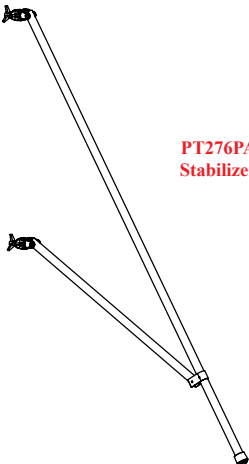

**PTF180TM**  
Toeboard

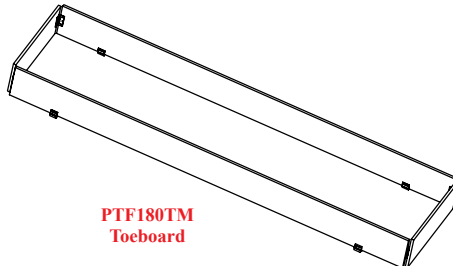



Prepared by: aęsan Merdiven Erisim Ekipmanları San. Tic. Ltd. Őti.

©2016 All rights reserved. Without the written permission of aęsan Merdiven, all or any part of this document may not be used, reproduced or copied without permission in printed form or in any other electronic media.

**agsan Merdiven Erisim Ekipmanları San. Tic. Ltd. Sti.**  
Dilovası Organize Sanayi Bolgesi 3. kısım , Meric Cad. No: 1  
Muallim Koyu, Gebze - Kocaeli / TURKEY

t: +90 262 759 18 08  
f: +90 262 759 18 78  
bilgi@agsanmerdiven.com.tr  
www.agsanmerdiven.com

