



Ladders and scaffold systems



Tanker Ladder





Tanker ladder Safe-comfortable- easy to use

KRAUSE is offering you a mobile tanker ladder used on road tankers for filling and cleaning and/or any other work occurring during these operations (e.g. sampling, service, repair).

The advantages of the ladder are a quick and safe ascendancy and the round railing. Hand rails on both sides for additional safe ascendancy.



„ While working on my new tanker ladder, I feel safe no matter what I do, sampling, servicing or cleaning. The ladder is very comfortable and quickly applicable due to its large basket -railing and platform. The ladder and its mechanics is easy to use, still it is robust. 

Dennis Müller, Tanker driver



Tanker ladder

Execution types and technical data

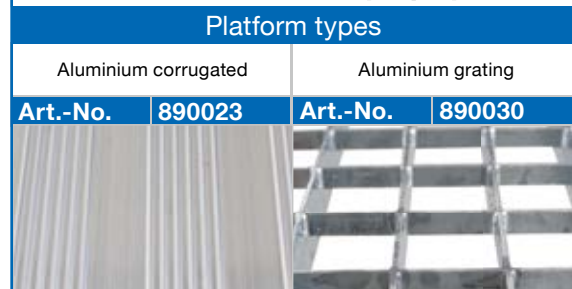
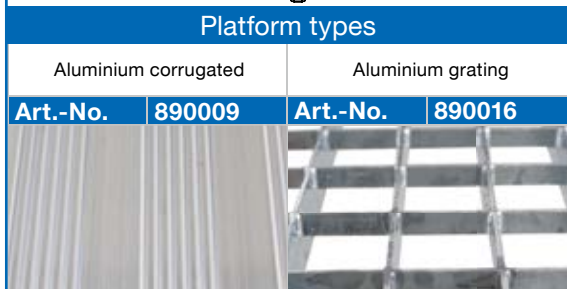
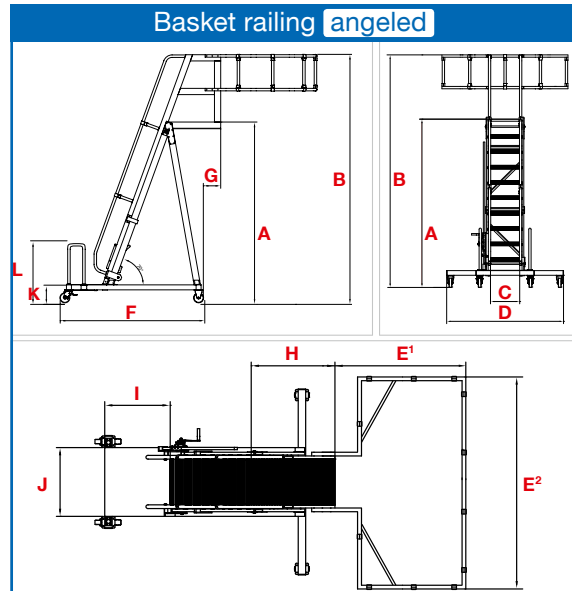
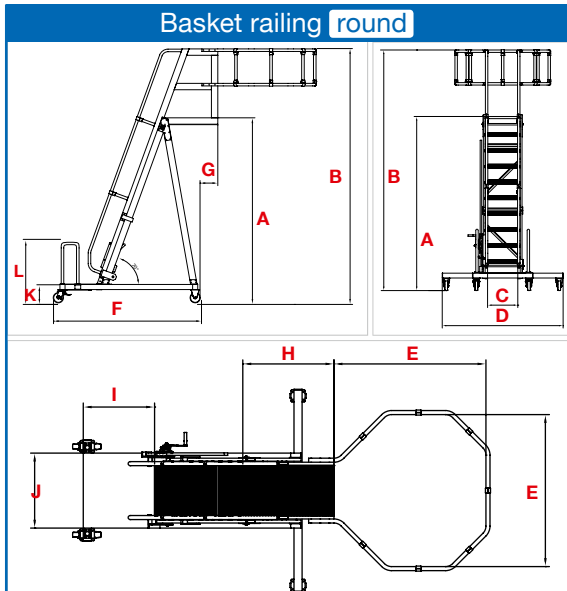

Technical details

A	Height of the platform	max. 4.200 mm min. 2.880 mm
B	Total height (with handrails)	max. 5.300 mm min. 3.980 mm
C	Width of steps/rungs	500 mm
D	Width of stabiliser	2.000 mm
E	Basket railing parameters	1.500 x 1.500 mm, dull edged angels
F	Chassis length	2.305 mm
G	Overhanging of the platform	ca. 275 mm bis 810 mm
H	Height of the upper platform	900 mm
I	Height of the lower platform	704 mm
J	Width of the lower platform	740 mm
K	Step up height	293 mm
L	Pushing hand rail (on the lower platform) with swivel castors (non-braked)	1.000 mm

Technical details

A	Height of the platform	max. 4.200 mm min. 2.880 mm
B	Total height (with handrails)	max. 5.300 mm min. 3.980 mm
C	Width of steps/rungs	500 mm
D	Width of stabiliser	2.000 mm
E¹	Basket railing parameters	1.500 mm
E²	Basket railing parameters	2.300 mm
F	Chassis length	2.305 mm
G	Overhanging of the platform	ca. 275 mm bis 810 mm
H	Height of the upper platform	900 mm
I	Height of the lower platform	704 mm
J	Width of the lower platform	740 mm
K	Step up height	293 mm
L	Pushing hand rail (on the lower platform) with swivel castors (non-braked)	1.000 mm

Accessory

The adjustable foot set on the chasses enables secure placement on uneven ground



Art.-No.	890108
----------	--------



Tanker Ladder Your Benefits

Particularly convenient...

- + for inspection works while filling and cleaning
- + for taking samples from a tanker or any other vehicle suitable for the transport of fluids
- + for safe ascendancy during cleaning, defrosting or maintenance works

Particularly convenient and effective...

- + stable, galvanized steel chassis with hand rail for comfortable movement
- + 500 x 900 mm large platform with hand rails on both sides
- + extendable high - adjustment (adjustment range from step to step-280mm) with minimal effort due to the rack bar and handle
- + the deeply overhanging platform provides safety while working on the tanker or silo





Tanker Ladder Your Benefits

Extremely safe...

- + both side hand rail for ascending and descending
- + large, extended basket railing, round 1500 x 1500 mm or angeled 2300 x 1500 mm
- + the steps are profiled and welded to the rails for safer ascendency
- + Self-locking levers which prevents the upper ladder section from accidental slip back
- + the rack bar accessory may be fixed in one position

Extremely easy usage...

- + easy to use rack bar (there is no risk of tearing or twisting of the steel cable)
- + it may be used immediately (ballast weight included in the package)
- + Supplied in pre-assembled modules (therefore it is easy to assemble)





KRAUSE-Werk GmbH & Co. KG

Am Kreuzweg 3 • D-36304 Alsfeld

Tel.: +49 (0) 66 31 / 7 95-0 • Fax: +49 (0) 66 31 / 7 95-139

E-Mail: info@krause-systems.de



KRAUSE-Systems AG

Chrümble 9 • CH-5623 Boswil

Tel.: +41 (0)56 666 90 50 • Fax: +41 (0)56 666 90 51

E-Mail: info@krause-systems.ch



KRAUSE Kft.

H-2030 Érd, Tolmács u. 5-7.

Tel.: +36 (06) 23 / 521 130 • Fax: +36 (06) 23 / 365 109

E-Mail: info@krause-systems.hu



KRAUSE Sp. z o. o.

ul. Stalowa 10 • PL - 58- 100 Świdnica

Tel.: +48 74 / 851-88-00 • Fax: +48 74 / 851-88-18

E-Mail: info@krause-systems.pl



ООО КРАУЗЕ-СИСТЕМС

RU-129090 Москва • ул. Гиляровского 4, стр. 5, офис 204

тел.: +7 (495) 640 46 56 • факс: +7 (495) 640 46 56

E-Mail: info@krause-systems.ru



ТОО „КРАУЗЕ-СИСТЕМС“

KZ-010000, г. Астана, • ул. Брусиловского 17/3

тел.: +7 (7172) 57 67 98 • факс: +7 (7172) 56 97 83

E-Mail: info@krause-systems.com.kz



Visit our web site:

<http://www.krause-systems.co.uk/>